

14-10 and Trademaster

Industrial bandsaws engineered for performance.

features

14-10:

■ **Designed** for high performance at a low price.

■ **Blade changes** are quick and easy.

■ **4 speeds** that are easily adjusted.

Trademaster:

■ **Adjustable blade feed pressure** supplies up to 60 lbs. of cutting pressure. This simple but effective system requires no additional motors or hydraulics, leaving it maintenance free.

■ **Power feed and tilt table combination** makes compound angle cutting easy and practical.

■ **Variable speed range.** 50-500 fpm continuous range. Speed indicator is clearly visible.



Trademaster Shown

specifications

model	number	blade width	blade length	blade speed	welder capacity	worktable travel distance	band wheels number	band wheels size	horsepower
		inches	inches	fpm					
14-10	88050/88051	1/4-1/2	120	70/140/270/540 (infinitely variable)			2	14	1
Trademaster	88070/88071	1/4-1	150	50-500	1/4-1	11	2	20	1 1/2

Specifications subject to change without notice.



For more information call 800-937-3253

model

14-10
Trademaster

standard equipment

- Work lamp (Trademaster only)
- One standard blade

optional equipment

- **Blade welder** with a 1" capacity is available for the Trademaster only.

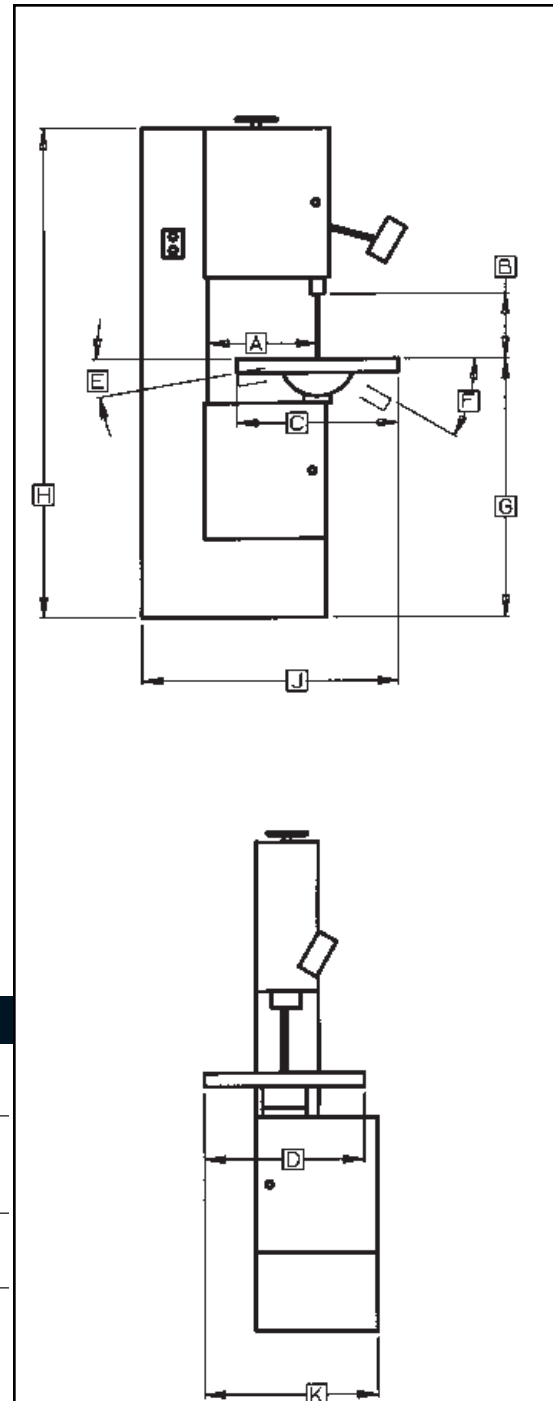

A	B	C x D	E x F	G	H	J x K	weight
<i>throat size (band to column)</i>	<i>maximum work height</i>	<i>worktable dimensions</i>	<i>worktable tilt</i>	<i>worktable height</i>	<i>machine height</i>	<i>machine floor space</i>	
<i>inches</i>	<i>inches</i>	<i>inches</i>	<i>left/right</i>	<i>inches</i>	<i>inches</i>	<i>inches</i>	<i>pounds</i>
14	10	15x16	5°/45°	42½	76	24x28	625
19½	12	24x24	10°/45°	41	80	40x32	1,050

Work-A-Matic SXC

Great for production and job shops.

features

- **Gravity feed.** The blade feeds into the material by gravity, which allows for hands-free operation.
- **Frame and base** are heavy duty welded steel for rigidity. Built to handle the toughest environments.
- **Fast set up.** Effortless changes between a cut off saw, contour saw and rip saw. Fast set up makes it ideal for production.
- **Variable feed rate system** with hydraulic feed regulator that features a convenient front mounted flow control valve. Cut almost any metal or other hard material—four blade speeds and infinitely adjustable blade pressure. Hydraulic feed regulator protects against shortened blade life.
- **Low voltage controls** with thermal overload and E-stop for emergency stop and start situations.
- **Enclosed guarding** for step pulley and bottom wheel assembly.



specifications

model	number	blade width	blade length	blade speed	A	B	cut capacity	electrics	horse power
					blade travel	maximum work height			
		inches	inches	f.p.m.	inches	inches	inches	phase	inches
SXC	88040/88041	1/4-3/4	120	70/140/270/540	9	14 1/2	9x14 1/2	1 or 3	1

Specifications subject to change without notice.



For more information call 800-937-3253

model

**Work-A-Matic
SXC**

standard equipment

- C-clamp assembly
- One standard blade

optional equipment

- **Heavy-duty casters.** Add mobility—move your Work-A-Matic to the work, then lock the casters for stability.

The **Work-A-Matic Saw** feeds into work by gravity

The ultimate all-use metal-cutting band-saw

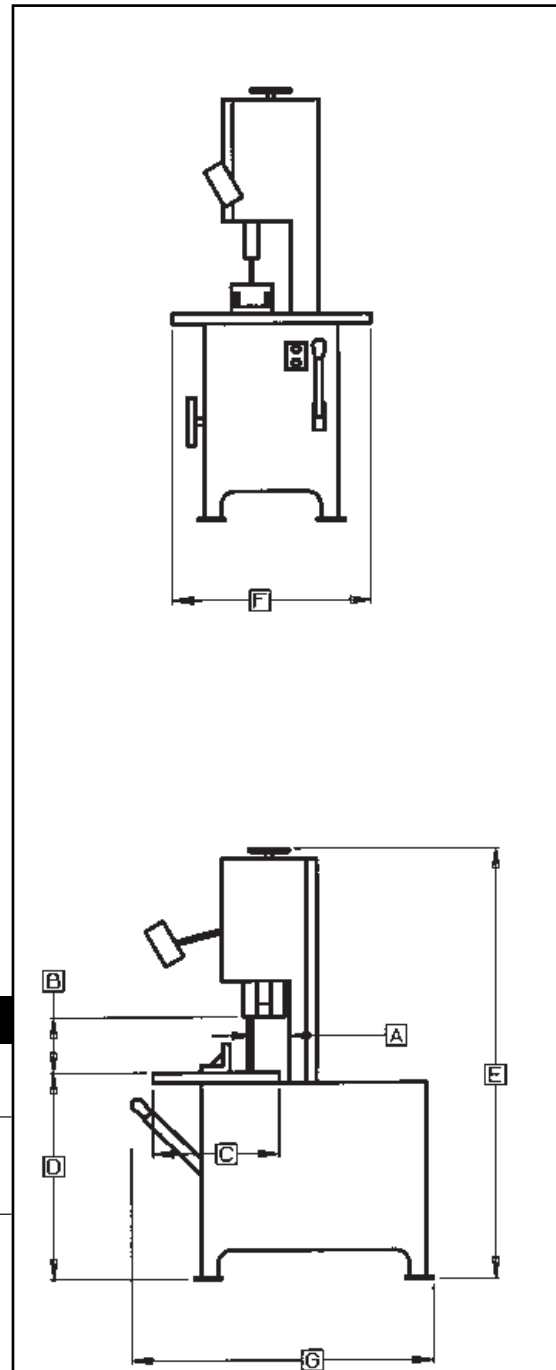
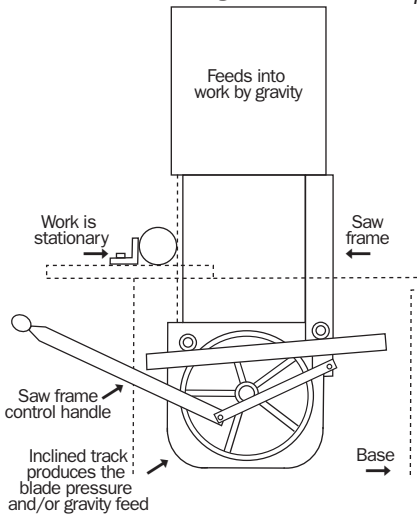

F x C	D	E	F	G	weight	
table precision ground	work height	wheel diameter	machine height	machine width	machine depth	
inches	inches	inches	inches	inches	inches	
29x18	36½	14	66	29	40	810 pounds

Vertical Bandsaws

For job shop or low production service, **Dake** has models for all materials.

features

F-16:

- **16" saw** for small-to-medium workpieces.

- **Set of blade guide inserts**

- **Same heavy-duty construction** as our larger saws.

V-24:

- **23" saw** for intermediate-size workpieces.

- **Blade tension indicator**

- **Contour cutting attachment**

- **Protractor**

- **High speed roller guides**

- **Adjustable worktable** (manual on V-24 and hydraulic on VH-24).

- **Auxiliary worktable** useful for handling larger workpieces.

V-40:

- **41" saw** for larger work requirements.

- **Throat size** of more than 40".

- **Auxiliary worktable** measuring 15½x21½".

- **Blade tension indicator**

- **Protractor**

- **High speed roller guides**

- **Adjustable worktable** (manual on V-40 and hydraulic on VH-40).

All Models:

- **Rip fence attachment (except F-16)**

- **Work lamp (except F-16)**

- **Tachometer**



Model VH-24 Shown

specifications

model	number	blade width	blade length	blade speed	welder capacity	worktable travel distance	worktable t-slots	band wheels number	band wheels size	horsepower
		inches	inches	infinitely variable	inches	inches			inches	
F-16	87016	1/8-5/8	130	60-550 fpm				2	16½	1.5
V-24	87001	5/16-1	183	50-425 fpm (low range) 425-4,250 fpm (high range)	5/16-1	10	4	2	24½	2.2
VH-24	87002	5/16-1	183	50-425 fpm (low range) 425-4,250 fpm (high range)	5/16-1	10	4	2	24½	2.2
V-40	87003	5/16-3/4	188	50-425 fpm (low range) 425-4,250 fpm (high range)	5/16-3/4	10	4	3	16½	2.2
VH-40	87004	5/16-3/4	188	50-425 fpm (low range) 425-4,250 fpm (high range)	5/16-3/4	10	4	3	16½	2.2

Specifications subject to change without notice.



For more information call 800-937-3253

model

- F-16**
- V-24**
- VH-24**
- V-40**
- VH-40**

standard equipment

- **A contour cutting attachment** is standard on the VH-24 and VH-40 hydraulic feed table models. With this feature it's a snap to hold and cut pieces with irregular profiles.
- **A protractor head attachment**, standard on Dake/Johnson 24 and 40 models allows exact settings for angle cuts ranging from 45° left to 45° right.
- **High speed roller guides**, for cutting non-ferrous materials, are furnished as standard equipment with the 24 and 40 models.

optional equipment

- **A circular cutting attachment** is optional for the 24 and 40 Dake/Johnson vertical saws. It allows easy cutting of discs up to 20" on all models.
- **Optional carbide guides** in different sizes for different widths of blades.

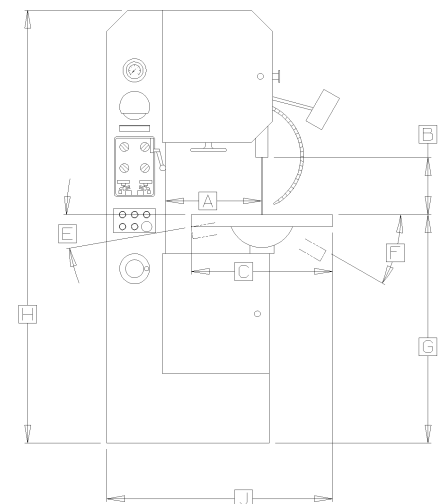
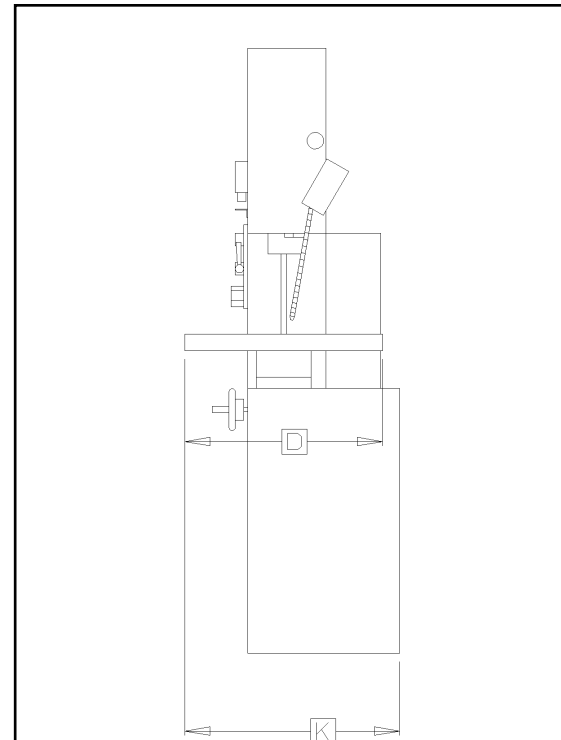

A	B	C x D	E x F	G	H	J x K	weight
throat size (band to column)	maximum work height	worktable dimensions	worktable tilt	worktable height	machine height	machine floor space	
inches	inches	left/right	inches	inches	inches	pounds	
16	11	23½ x 23½		37½	72	38 x 25	975
23	13	26¾ x 26¾	10°/30°	42	90	60 x 60	2,025
23	13	26¾ x 26¾	10°/30°	42	90	60 x 60	2,140
41	13	26¾ x 26¾	10°/30°	40⅞	78	72 x 60	2,345
41	13	26¾ x 26¾	10°/30°	40⅞	78	72 x 60	2,460