

Power Hammer

Built tough for the metalworking craftsman.



For more information call 800-937-3253

features

- **Ideal tool** for fabricating one-of-a-kind or impossible-to-find replacement parts.
- **Design and form** custom hot rod, motorcycle, aviation, and sheet metal parts in your own shop.
- **16 gauge steel capacity.**
- **11 gauge aluminum capacity** (annealed 3003H14.)
- **7" maximum opening** with infinitely adjustable bottom die holder.
- **Wheels on base** included for portability and storage.

standard equipment

- **One set** of thumbnail shrinking dies.
- **Die set:** industry standard 3/4" (19mm) square tool post for standard shrinking or stretching square shank die sets.
- **Manual, instructional video** and one year warranty.

optional equipment

- **For additional tooling,** please consult factory.

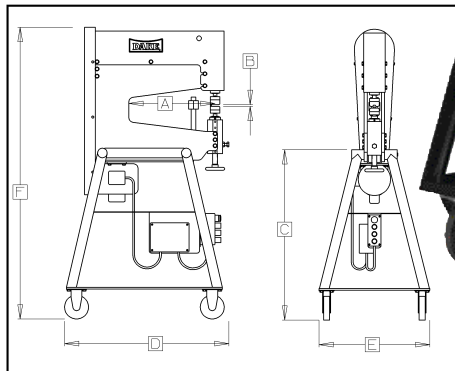
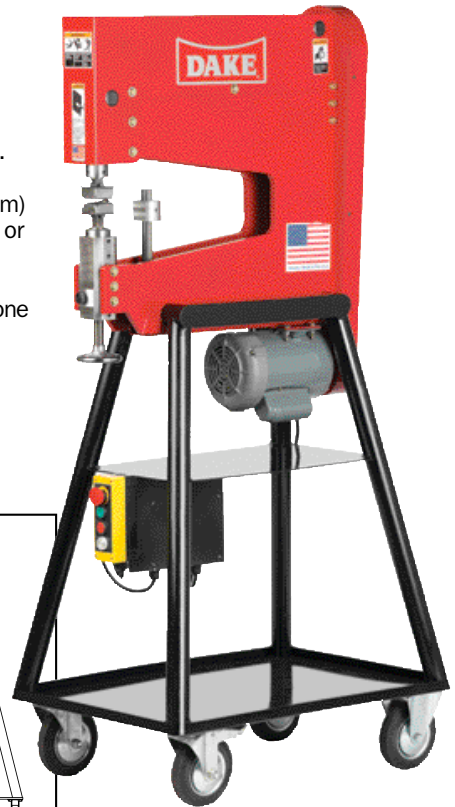

specifications

model	part #	capacity	electrics	horse power	hammer speed	throat	max. opening	floor to hammer	base	height	weight
		gauge			fpm	inches	inches	inches	inches	inches	pounds
80100	H100	16 steel	120V	1	900	18	7	36 ³ / ₄	24x33	67	520
		11 alum.									

Specifications subject to change without notice.